

## Enclosed Motor Construction Heater

EMC



Sealed Motor



### Features

#### Powerful Heating

Delivers powerful heat output with a propeller type fan, accurately balanced and correctly pitched to optimize performance.

#### Safe

Thermal overheat protection for safety.

#### Stainless Steel Tubular Element

Stainless steel tubular element produces safe and efficient heat.

#### Prevents Dust

Enclosed motor design prevents accumulation of dust and extends motor life.

#### Temperature Control

Double pole thermostat is built-in with temperature range of 5-57°C (41-135°F).

#### Durable Finish

Polyester/epoxy powder coating resists fading and abrasion.

#### Includes Cord

Includes 6 foot cord with NEMA standard plug (3-30P).

#### Applications

Portable heat for workshops, garages, or construction sites.

### Dimensions

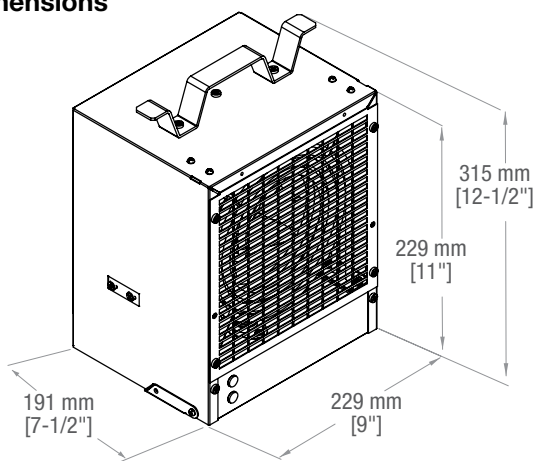

3 prong polarized plug 30 Amp

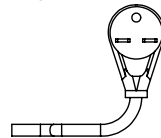

### Ordering Guide

Cat. No.	UPC	Color	Volts	Watts	BTU	CFM	Carton Dimensions (W x H x D)	Weight (kg/lbs.)	Wty.
EMC4240G	781052 119963	Grey	240	4800	16377	300	10.5" x 13.8" x 9.25" (26.7cm x 35.1cm x 23.5cm)	4.95 / 10.9	1 yr.