

INDUSTRIAL UNIT HEATER

Ideal for retrofit or new construction, the EUH series are perfect for supplemental heating in hard-to-heat areas. Easy, low-cost installation and low maintenance make them the right choice for years of dependable service.

BENEFITS

- Extensive selection of models ranging from 3 to 10kW
- Built-in adjustable thermostat on all models
- Ceiling hanger bracket included, optional wall bracket available (allows swivel movement)
- Five-way adjustable louvers to direct airflow
- Dimplex EUH series unit heaters are cULus approved for vertical and horizontal mounting
- Fully-enclosed element with spiral steel elements
- Sealed ball-bearing motors for long-service life



APPLICATIONS

Shipping / Receiving Areas | Warehouse Storage Areas | Garages

DIMENSIONS

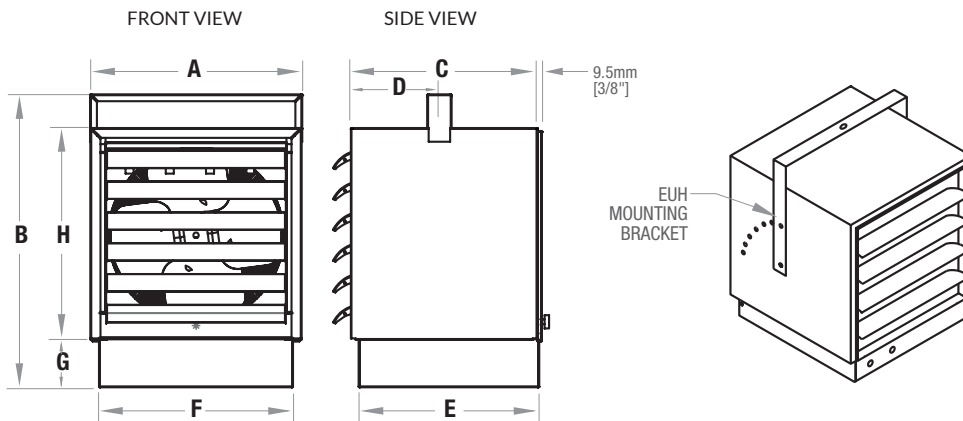

Model	A	B	C	D	E	F	G	H
EUH	330 mm 13"	495 mm 19-1/2"	330 mm 13"	165 mm 6-1/2"	318 mm 12-1/2"	299 mm 11-3/4"	64 mm 2-1/2"	330 mm 13"

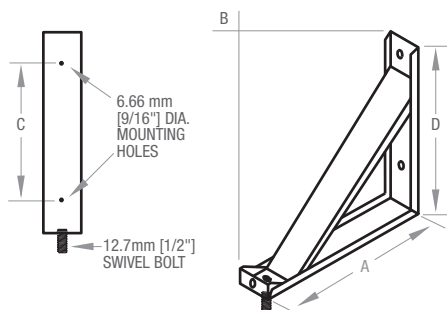

Hanger Bracket				
Model	A	B	C	D
EUHWB	318 mm 12-1/2"	356 mm 14"	203 mm 8"	279 mm 11"

SPECIFICATIONS

Voltage	120V, 208V, 240/208V, 480V, 600V 1/3 phase
Wattage	3 -10kW
Color	Almond
Finish	Powder coating resists fading and abrasion
Construction	Constructed of 18 gauge die formed steel. Units have individual adjustable 20 gauge convex profile air directing louvers. Louvers are friction fastened to a single piece 20 gauge frame to prevent movement, once adjusted to the desired position.
Installation	Vertical or horizontal mounting
Heating Element	Includes metal tubular sheath fused with spiral steel fin. Contains a high quality nickel chromium wire, encased in solidly packed magnesium oxide insulation.
Motor & Fan	Fan size and pitch is matched to the power and speed of the unit to optimize CFM, airflow, temperature rise, and quietness. Motor is heavy duty, continuous operation, totally enclosed, thermally protected with permanently lubricated ball bearings.
Warranty	1-year warranty on complete unit

ACCESSORIES *(field installed)*

Cat. No.	Description
EUHWB	Wall hanger bracket for EUH series (3-10kW)



ORDERING GUIDE

Cat. No.	kW	BTU	Volts	Phase	CFM	Weight (kg/lbs.)
EUH03B11T	3	10236	120	1	350	16.0 / 36
EUH03B24CT	3	10236	208	1/3	350	16.0 / 36
EUH03B31T	3 / 2.3	10236 / 7677	240 / 208	1	350	16.0 / 36
EUH03B34CT	3 / 2.3	10236 / 7677	240 / 208	1/3	350	16.0 / 36
EUH03B73CT	3	10236	480	3	350	18.0 / 40
EUH03B81CT	3	10236	600	1	350	18.0 / 40
EUH04B31T	4	13648	240	1	350	16.0 / 36
EUH05B24CT	5	17060	208	1/3	350	16.0 / 36
EUH05B31T	5 / 3.8	17060 / 12795	240 / 208	1	350	16.0 / 36
EUH05B34CT	5 / 3.8	17060 / 12795	240 / 208	1/3	350	16.0 / 36
EUH05B74CT	5	17060	480	1/3	350	18.0 / 40
EUH05B84CT	5	17060	600	1/3	350	18.0 / 40
EUH08B24CT	7.5	25590	208	1/3	600	21.0 / 46
EUH08B34CT	7.5 / 5.6	25590 / 19193	240 / 208	1/3	600	21.0 / 46
EUH08B74CT	7.5	25590	480	1/3	600	22.0 / 50
EUH08B84CT	7.5	25590	600	1/3	600	22.0 / 50
EUH10B24CT	10	34120	208	1/3	600	21.0 / 46
EUH10B34CT	10 / 7.5	34120 / 25590	240 / 208	1/3	600	21.0 / 46
EUH10B74CT	10	34120	480	1/3	600	22.0 / 50
EUH10B84CT	10	34120	600	1/3	600	22.0 / 50

Note: T = Built-in thermostat, CT = Built-in thermostat and contactor.

Built-in single pole thermostat controls are standard up to and including 10kW models.

Units showing 1/3 phase are field convertible to desired phase.

208V units have 208V control voltage, 240V control on all others.

Transformers are provided where necessary.